



Ender-3 3D Printer

User Manual

- ◆ This Manual is for the Ender-3 3D printer.
- ◆ Select the correct input voltage to match your local mains (230V or 115V)
- ◆ Because of software/hardware upgrades and model differences, new revisions may not be listed in this guide.
- ◆ Detailed instructions for use are available in the TF card.



V.2.1

Notes

1. Do not use the printer in other wrong ways to avoid personal injury or property damage.
2. Do not place the printer near any heat source or flammable or explosive objects. We suggest placing it in a well-ventilated, low-dust environment.
3. Do not expose the printer to violent vibration or any unstable environment, as this may cause poor print quality.
4. Before using experimental or exotic filaments, we suggest using standard filaments such as ABS or PLA to calibrate and test the machine.
5. Do not use any other power cable except the one supplied. Always use the three-pin plug .
6. Do not touch the nozzle or printing surface during operation as they may be hot. Keep hands away from machine while in use to avoid burns or personal injury.
7. Do not wear gloves or loose clothing when operating the printer. Such cloths may become tangled in the printers moving parts leading to burns, personal injury, or printer damage.
8. When cleaning debris from the printer hotend, always use the provided tools. Do not touch the nozzle directly when heated. This can cause personal injury.
9. Clean the printer frequently. Always turn the power off when cleaning, and wipe with a dry cloth to clean dust, adhered printing plastics or any other material from the frame, guide rails, or wheels . Use glass cleaner or isopropyl alcohol to clean the print surface before every print for consistent results.
10. Children under the age of 10, should not use the printer without any supervision.

Contents

1. Introduction	1	5. Software Installation	5
2. Screen Information	2	6. Preparing to Print.....	6
3. Loading Filament	3	7. Trouble-Shooting	7
4. Bed Levelling	4	8. Circuit Wiring Diagram	8

Preface

Dear Customers:

Thank you for choosing our products. For the best experience, please read the instructions before operating the Printer. Our 3D team is always ready to provide you with assistance. Please contact us via the phone number or e-mail address provided at the end when you encounter any problem with the Printer.

For a better experience in using our product, you may learn how to use the Printer in the following ways:

1. Learning from the instructions and videos that come with your TF card.
2. Visit our official website www.creality3d.cn. You will find relevant software/hardware information, contact details and operation and maintenance instructions on the website.

1. Introduction

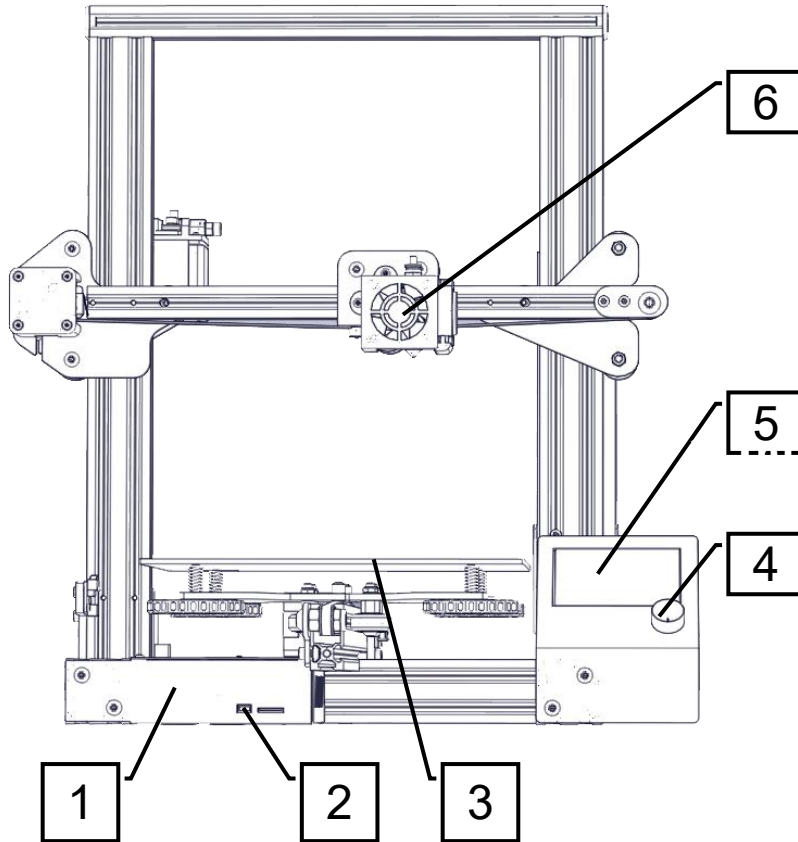

- | | |
|-------------------------|--------------------|
| 1. Control Box | 5. Display |
| 2. TF Slot and USB Port | 6. Nozzle Assembly |
| 3. Print Surface | |
| 4. Control Knob | |

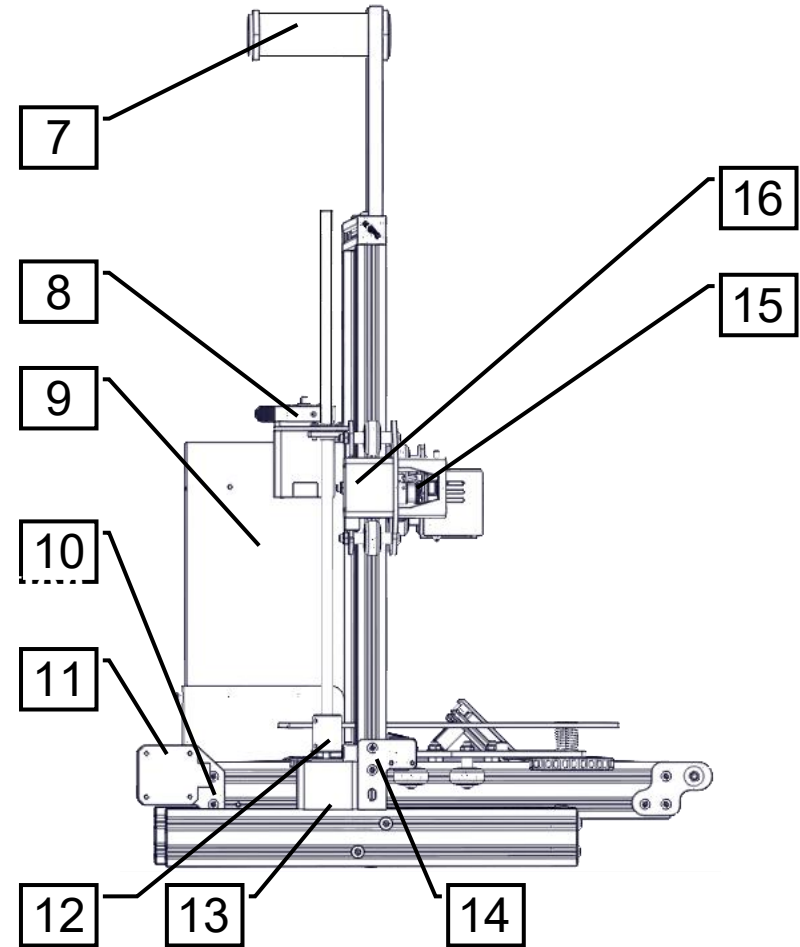

- | | |
|--------------------|--------------------|
| 9. Power | 13. Z Stepper |
| 10. Y Limit Switch | 14. Z Limit Switch |
| 11. Y Stepper | 15. X Limit Switch |
| 12. Coupling | 16. X Stepper |

2. Screen Information

Information Displayed

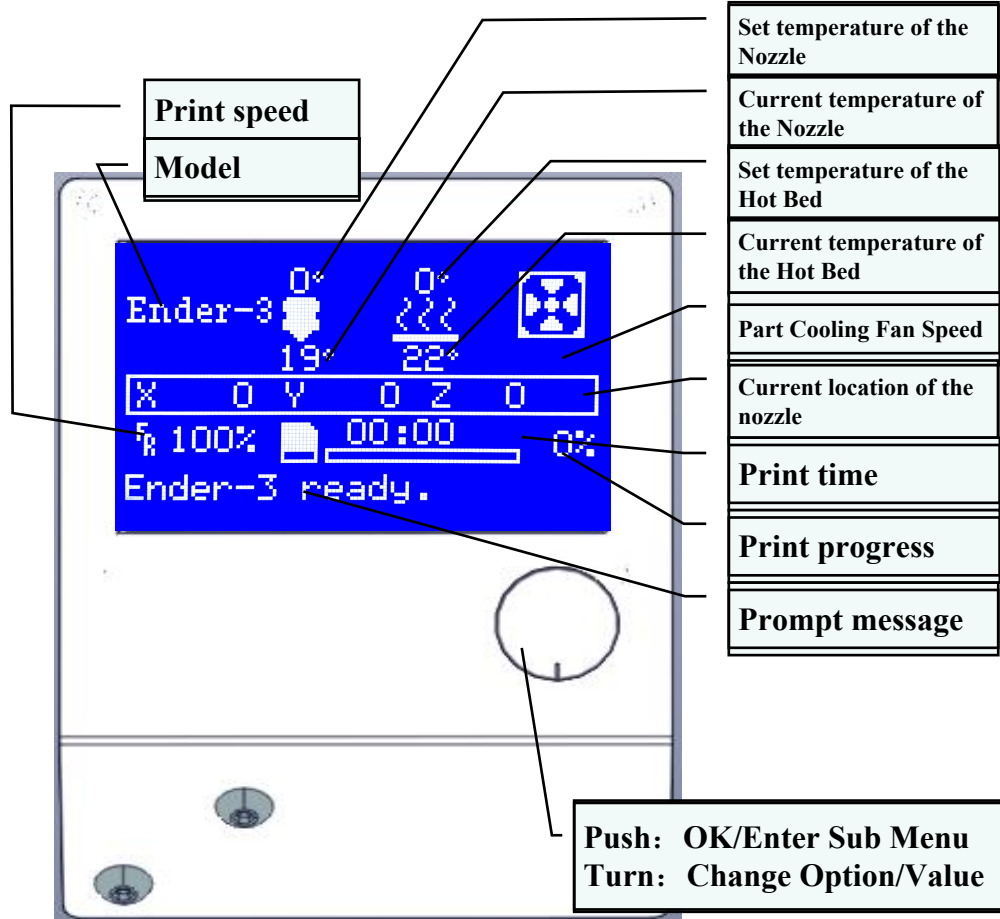

Common Functions		
Menu	Sub Menu	Explanation
↑ Info Screen ↑	↑ main ↑	Return
Prepare→	Move axis→	Moving X Y Z axis or Extruder by given value
	Auto home	Return to the origin
	Set home offsets	
	Disable steppers	Moving X Y Z axis by your hands
	Preheat PLA	
	Preheat ABS	
Control→	Cooldown	Close and cooldown the nozzle
	Temperature→	Heat the nozzle and the bed or change fan speed by given value
No TF card /Print from TF	Select the printing model	
Init.TF-Card /Change TF-Card		
About Printer		
Printing		
Tune→	Speed	Change Printing Speed by given value
	Nozzle	Change the temperature by given value
	Bed	Change the temperature by given value
	Fan Speed	Change Fan Speed by given value
	Flow	Change filament flow by given value
	Change filament	
Pause print		
Stop print		

3. Loading Filament

1. Preheat

Method 1

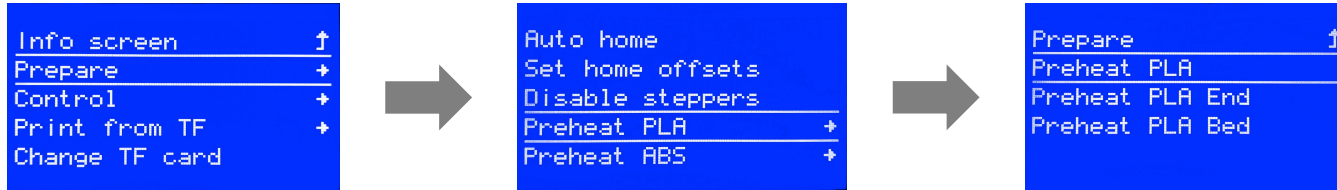

Method 2

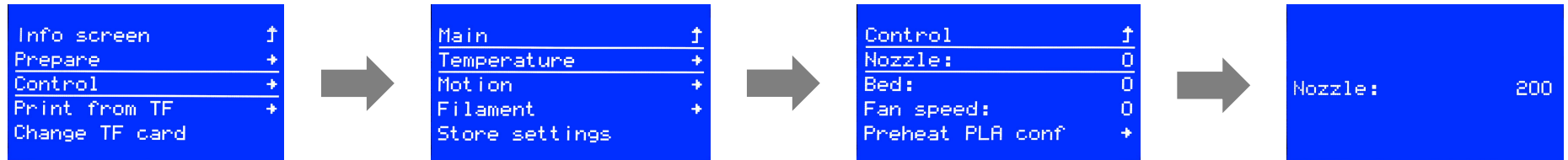

2. Feeding

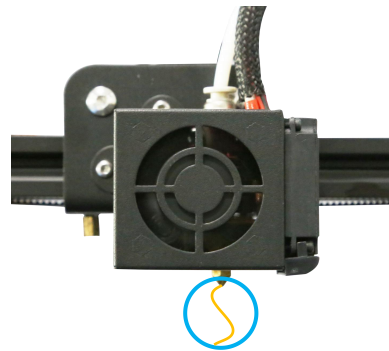
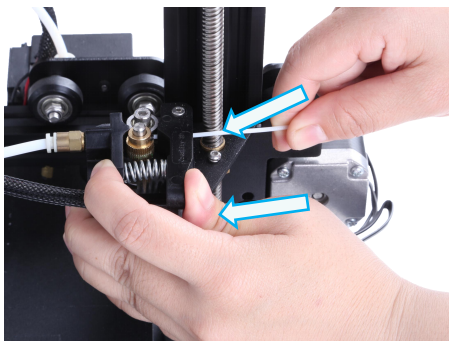

Tip: Replacing the Filament

- 1、Cutting filament near the Extruder and slowly feed new filament until the new filament get into the PTFE tube.
- 2、Preheating the nozzle, Press and hold the extruder, extract the filament, then feed the new filament.

Press and hold the extruder lever then insert 1.75mm filament through the small hole of the extruder. Continue feeding until you see filament out of the nozzle.

4. Bed Levelling

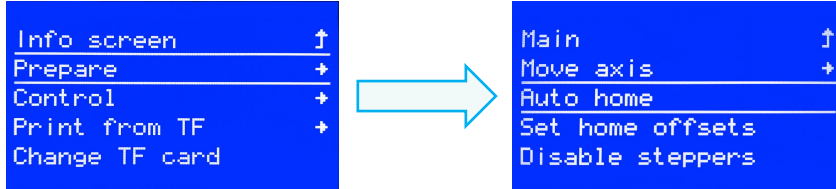

1. Prepare → Auto Home. Wait for the nozzle to move to the left/front of the platform.

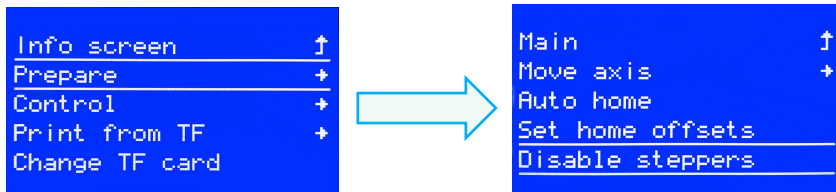

2. Prepare → Disable Steppers

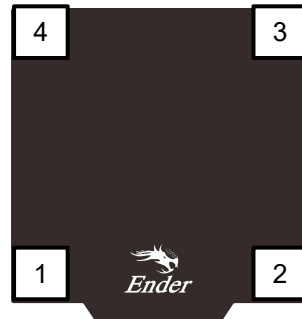
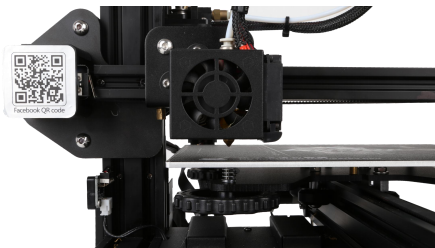

3. Move the nozzle to the front/left leveling screw and adjust the platform height by turning the knob underneath. Use a piece of A4 paper (standard printer paper) to assist with the adjustment, making sure that the nozzle lightly scratches the paper.

4. Complete the adjustment on all 4 corners
5. Repeat above steps 1-2 times if necessary.

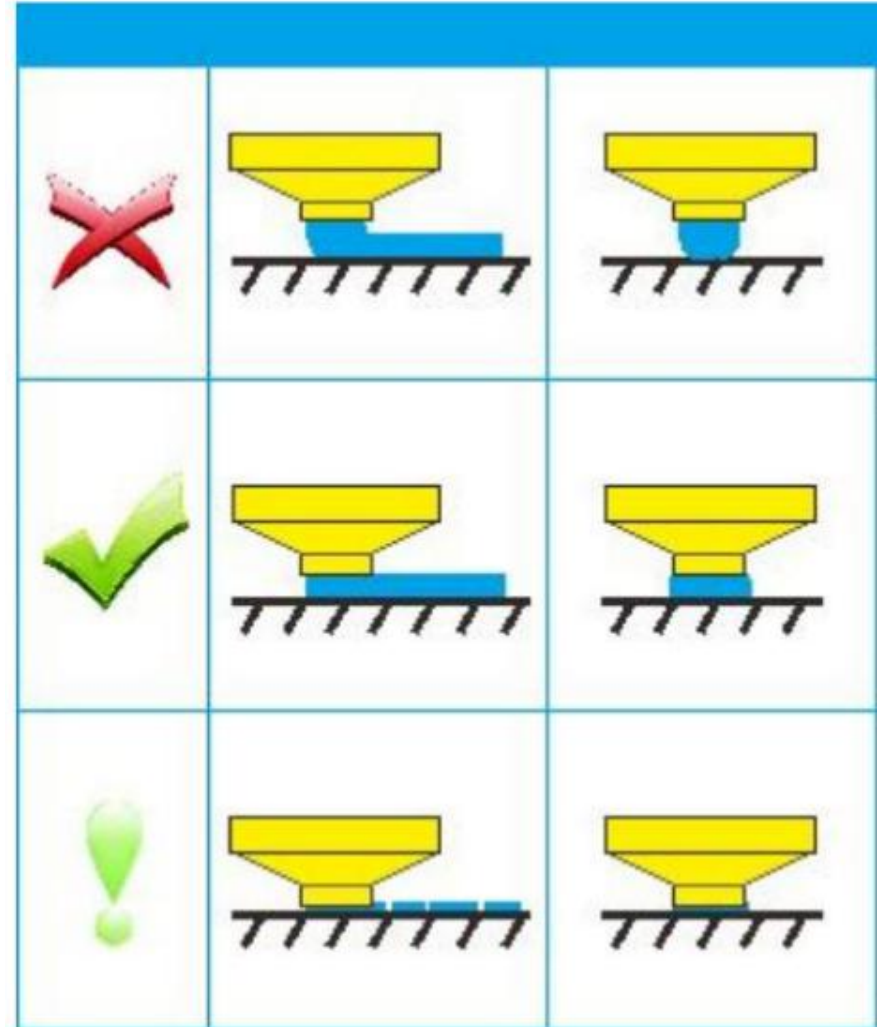

5. Software Installation



Creality
Slicer_1.2.3

1. Double click to install the software.



Creality Slicer

2. Double click to open the software.

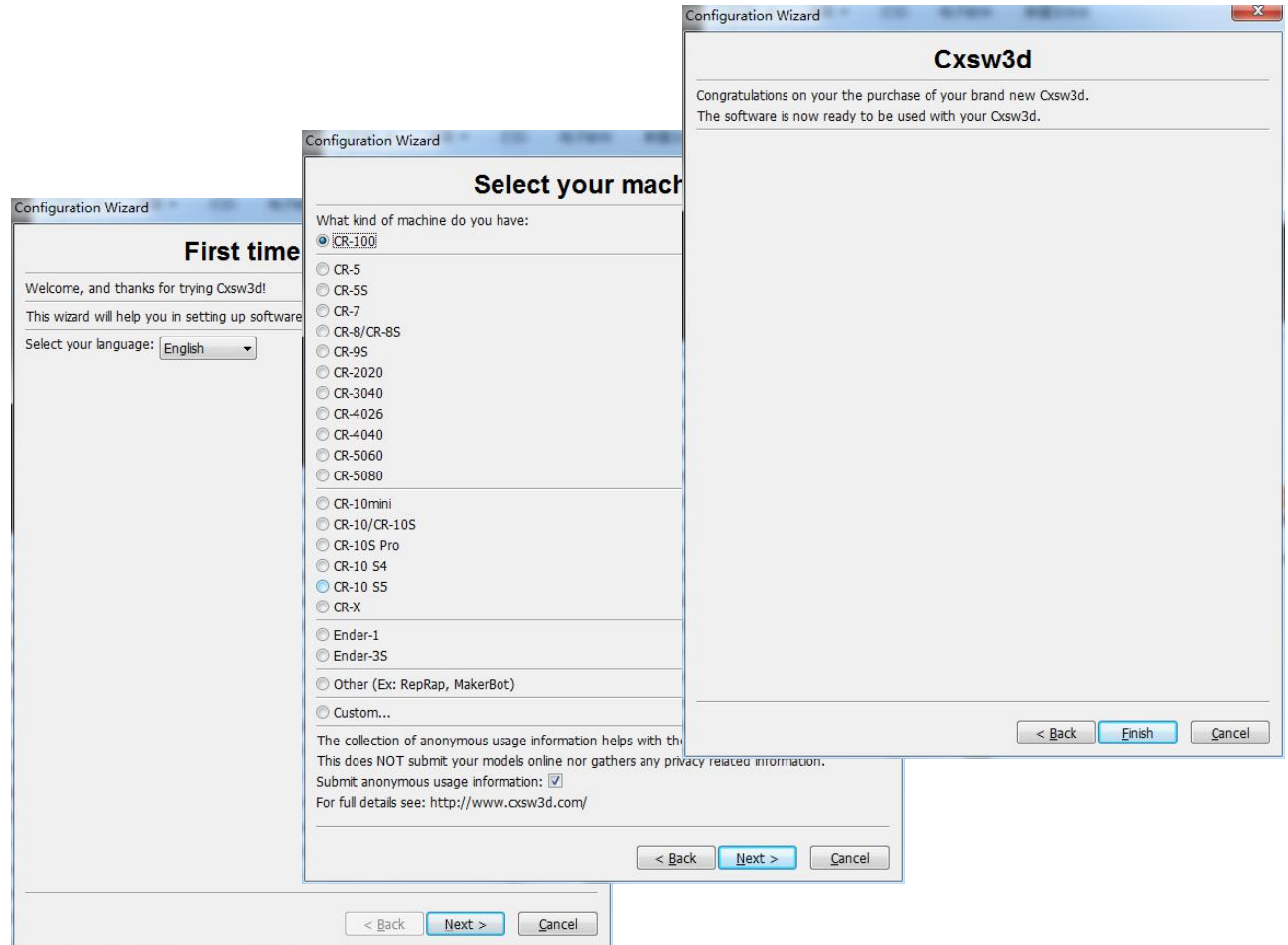

3. Select language→Next→Select your machine→Next→Finish.

6. Preparing to Print

1.Slicing

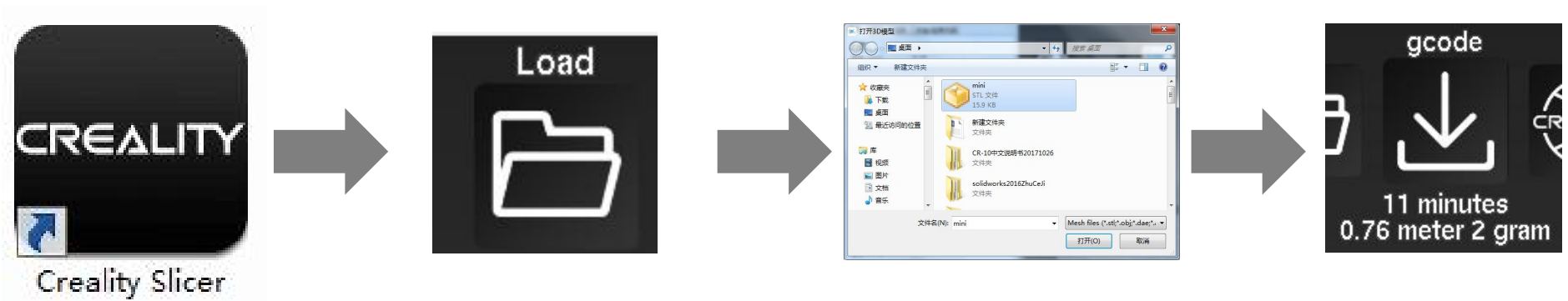

Open the software→Load→Select the file→Wait for slicing to finish ,and save the gcode file to TF card.

2.Printing

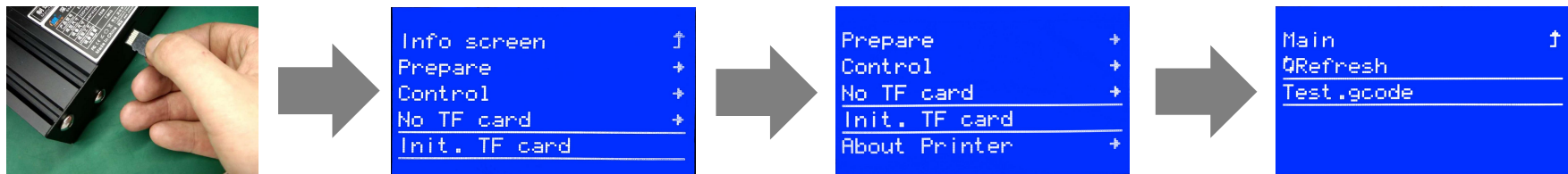

Insert the TF card→ Int. TF-Card → Print from TF→Select the file to be printed.

7. Trouble shooting

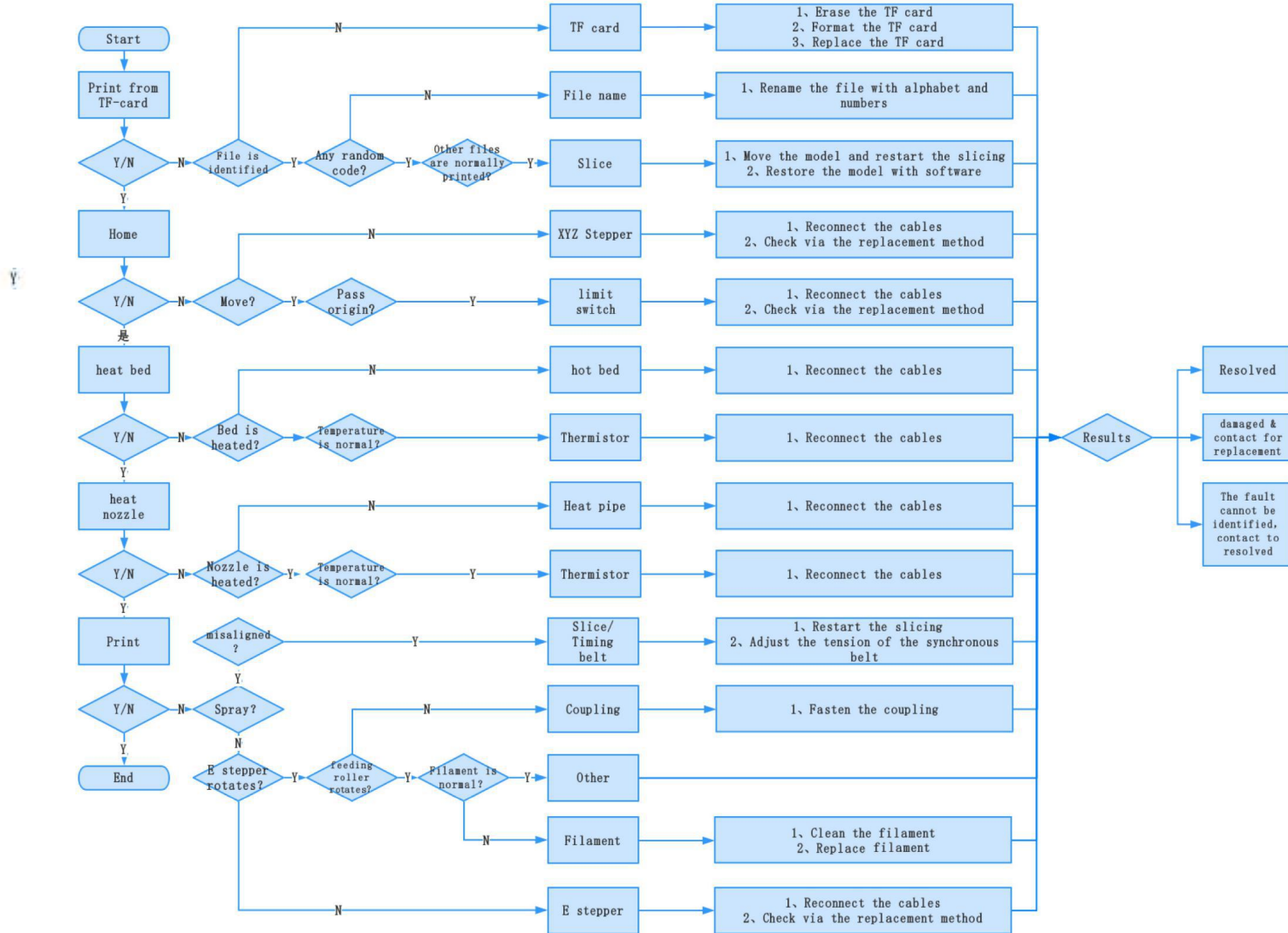

8. Circuit Wiring Diagram

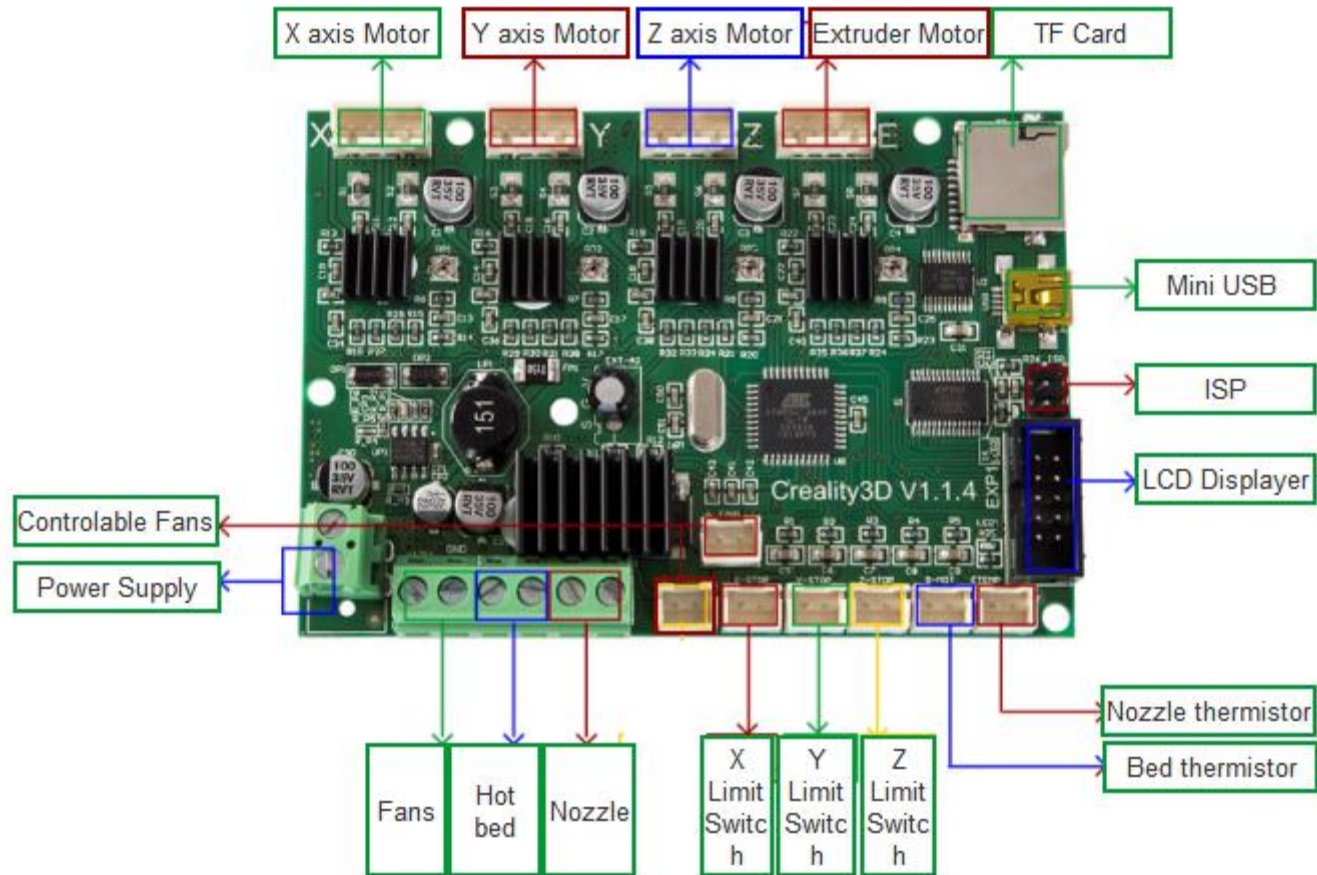

After- Sales Service

Service

1, The printer can be returned within seven days, 15 days replacement, one year warranty, lifetime maintenance.

Replacement requirement

1. The appearance of the product is intact, without damage, scratches, smudges, cracks, deformation, etc.;
2. Machine parts, tools and others are complete;
3. Provide a complete and valid purchase invoice and warranty, product number should be the same.

Warranty coverage

1. The following accessories are not included in the warranty coverage if they are not damaged by transportation: platform sticker; platform forming plate; acrylic cover; card reader and TF card; platform glass; USB cable; filament; rack and tools,etc.
2. Profile: Before we deliver the goods, we will do the machine test, so maybe there will be light scratch, or due to long-distance transportation, which scratch the profile a little bit. in the premise of not affecting the normal use, in principle, not within the scope of warranty;
3. Nozzle assembly (nozzle, heating block, throat pipe,heat sink, Teflon tube, etc.) warranty period is 3 months, if it is damage after the warranty expires, you need to purchase another one;
4. Motherboard, LCD display, power supply, hot bed,warranty period is 12 months, if there are quality problems, you can get free maintenance; over the warranty period, can be sent back to the original factory maintenance, the users need to bear the return shipping and maintenance costs;
5. Not included in warranty coverage:
 - (1) It is not possible to provide an effective after-sales service card or serial number;
 - (2) The whole machine and components exceed the warranty period;

- (3) Equipment failure or damage caused by unauthorized modification of the equipment (private modification includes: 1. modification of the nozzle assembly; 2. modification of the machine structure; 3. use of third-party components; 4. use of third-party firmware procedures or change the original Factory firmware program, etc.);
- (4) Equipment failure or damage due to incorrect installation and use;
- (5) Equipment failure or damage caused by the use of the equipment in a working environment not specified by the product;
- (6) Equipment failure or damage due improper use (beyond workload, etc.) or maintenance (moisture, etc.);
- (7) Equipment failure or damage due to the use of other branded components or low quality consumables.

Statement:

For better highlighting the function and effectiveness of 3d printer and promoting the development of global market economic, strengthening the user self-discipline of 3d industry and establishing a good image of 3d printing, since Creality 3d printer have passed all kinds of authorized product certificates and quality management system.hereby we declare that it is strictly forbidden to use our printer to print any products or equipment that are in violation of the specific country and regions legislation.



SHENZHEN CREALITY 3D TECHNOLOGY CO.,LTD.
11F & Room 1201,Block 3,JinChengYuan,Tongsheng Community,Dal
ang,Longhua District,Shenzhen,China,518109
Official Website: www.creality.com
Tel: +86 755-85234565
E-mail: info@creality.com cs@creality.com

